

Memory Module Specifications

KF548S38IB-32TR

32GB 4G x 64-Bit

DDR5-4800 CL38 262-Pin SODIMM

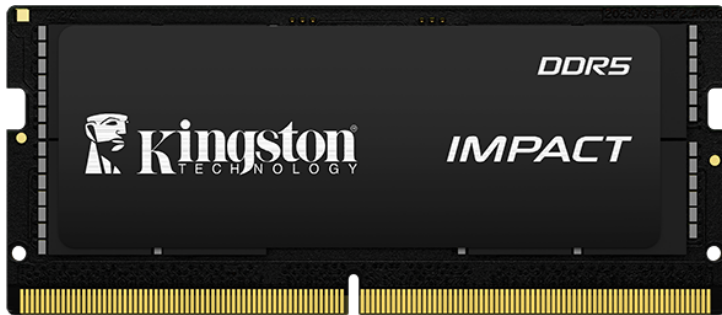

DEFAULT SPECIFICATIONS

CL(IDD)	38 cycles
Row Cycle Time (tRCmin)	48ns(min.)
Refresh to Active/Refresh Command Time (tRFCmin)	295ns(min.)
Row Active Time (tRASmin)	29.12ns(min.)
UL Rating	94 V - 0
Operating Temperature	0° C to +85° C
Storage Temperature	-55° C to +100° C

DESCRIPTION

Kingston KF548S38IB-32TR is a 4G x 64-bit (32GB) DDR5-4800 CL38 SDRAM (Synchronous DRAM) 2Rx8, memory module, based on sixteen 2G x 8-bit FBGA components per module. The module supports Intel® Extreme Memory Profiles (Intel® XMP) 3.0. Each module has been tested to run at DDR5-4800 at a low latency timing of 38-38-38 at 1.1V. Additional timing parameters are shown in the Plug-N-Play (PnP) Timing Parameters section below. Each 262-pin DIMM uses gold contact fingers. The JEDEC standard electrical and mechanical specifications are as follows:

DEFAULT FEATURES

- Power Supply: VDD = 1.1V Typical
- VDDQ = 1.1V Typical
- VPP = 1.8V Typical
- VDDSPD = 1.8V to 2.0V
- On-Die ECC
- Height 1.18" (30mm)

Note: The PnP feature offers a range of speed and timing options to support the widest variety of processors and chipsets. Your maximum speed will be determined by your BIOS.

FACTORY TIMING PARAMETERS

- Default (Plug N Play): DDR5-4800 CL38-38-38 @ 1.1V
- XMP Profile #1: DDR5-4800 CL38-38-38 @ 1.1V

Continued >>

MODULE DIMENSIONS

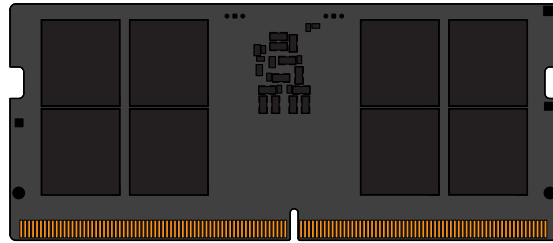
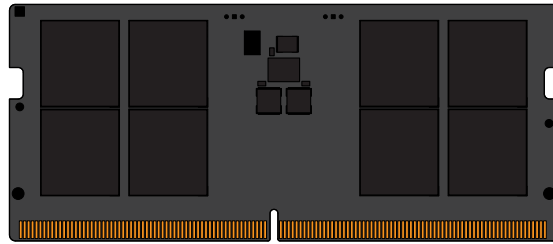

All measurements are in millimeters.
(Tolerances on all dimensions are ± 0.15 unless otherwise specified)

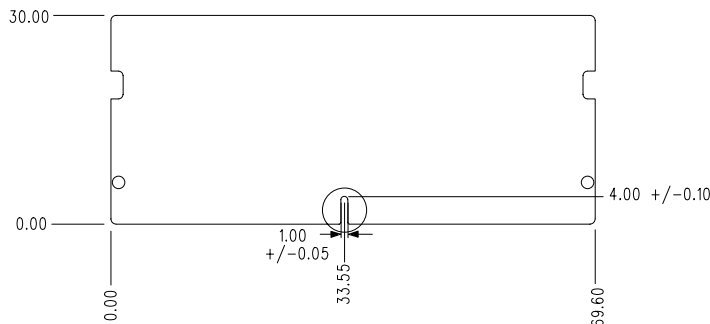

The product images shown are for illustration purposes only and may not be an exact representation of the product. Kingston reserves the right to change any information at anytime without notice.

FOR MORE INFORMATION, GO TO KINGSTON.COM

All Kingston products are tested to meet our published specifications. Some motherboards or system configurations may not operate at the published Kingston memory speeds and timing settings. Kingston does not recommend that any user attempt to run their computers faster than the published speed. Overclocking or modifying your system timing may result in damage to computer components.